

## ISO 12836: 牙科数字化设备

此标准描述了测试牙科数字化设备准确性的方法，以验证其质量、可靠性和准确性。ISO 12836 是对牙科设备供应商进行评定以在牙科市场内提升质量的标准。

# ISO 12836 - Dentistry, Digitizing devices used in CAD/CAM systems

By: **Avi Cohen** – Head of Medical Solutions, *Objet Geometries Ltd.*

The dental industry is moving quickly towards digital dentistry and 3D technologies. Designed to help you to get the most from digital solutions, *Objet Geometries* - the innovation leader in 3D printing - has developed a range of dental 3D printing solutions.

*Objet's* 3D printing solutions enable dental labs to maximize the advantages from their digital dentistry investments. With 3D printing at your fingertips you can rapidly and accurately create dental appliance models and change for the better the dental experience for patients everywhere.

As such, *Objet Geometries* - the innovation leader of 3D printing solutions has been certified for the ISO13485:2003 certification for medical devices. ISO 13485 specifies requirements for a comprehensive quality management system for the design and development, production, installation and servicing of medical devices. This international standard confirms *Objet's* ability to provide the medical industry with 3D printers and related services that meet the regulatory requirements applicable to medical devices.

At *Objet*, we are very committed to the medical industry and to meeting our medical and dental customers' expectations while adhering to strict regulatory compliance regulations. ISO standards certification validates our consistent obligation to high-quality 3D printing systems and processes and provides independent confirmation that our Quality Management System (QMS) is in full compliance with industry and regulatory standards.

Now, with coming draft of ISO12836, Dentistry – Digitizing devices used in CAD/CAM systems, the digital industry becomes more standardized. This standard describes methods for testing the accuracy of dental digitizing devices in order to verify their quality, reliability and accuracy. ISO12836 can become the standard against which dental device suppliers are measured to drive quality within the dental market.

The addition of **ISO12836** complements major existing ISO standards for the dental industry and remains a major strategic focus for *Objet Geometries* as **ISO12836** represents an important milestone, further supporting our vision to be recognized for 3D printing solutions for the ongoing manufacturing of commercial dental arena.

This draft has been developed within the International Organization for Standardization (ISO), and processed under the ISO-lead mode of collaboration as defined in the Vienna Agreement.

This draft is hereby submitted to the ISO member bodies and to the CEN member bodies for a parallel five-month enquiry.

Should this draft be accepted, a final draft, established on the basis of comments received, will be submitted to a parallel two-month approval vote in ISO and formal vote in CEN.

In accordance with the provisions of Council Resolution 15/1993 this document is circulated in the English language only.

THIS DOCUMENT IS A DRAFT CIRCULATED FOR COMMENT AND APPROVAL. IT IS THEREFORE SUBJECT TO CHANGE AND MAY NOT BE REFERRED TO AS AN INTERNATIONAL STANDARD UNTIL PUBLISHED AS SUCH.

© International Organization for Standardization, 2011

## ISO 12836 - Dentistry, Digitizing devices used in CAD/CAM systems

### Inlay shaped specimen for form reproduction testing

The dimensions are:

- a =  $(7 \pm 0,5)$  mm
- b =  $(5 \pm 0,5)$  mm
- c =  $(16 \pm 1)$  mm
- e =  $(5 \pm 0,5)$  mm
- $\alpha$  =  $(16 \pm 1)^\circ$
- x = 0,02 mm
- y = 0,02 mm
- z = 0,02 mm

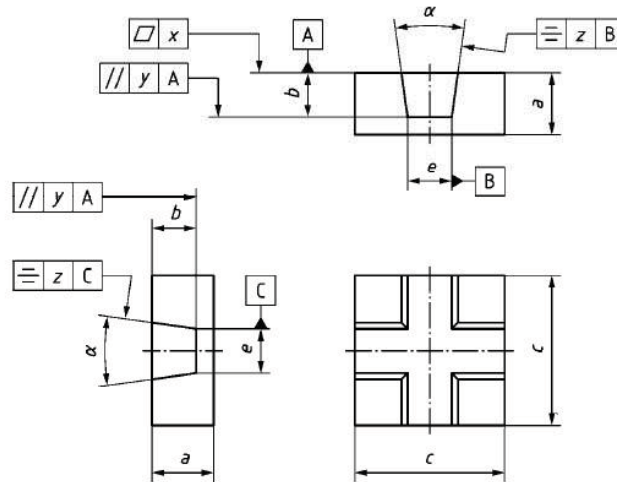

### Areas to be considered

Dimensions of the hatched areas:

- h = 2 mm
- j = 3,5 mm
- k = 0,5 mm
- m = 8 mm

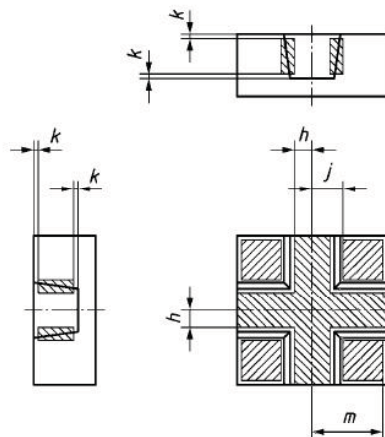

This draft has been developed within the International Organization for Standardization (ISO), and processed under the ISO-lead mode of collaboration as defined in the Vienna Agreement.

This draft is hereby submitted to the ISO member bodies and to the CEN member bodies for a parallel five-month enquiry.

Should this draft be accepted, a final draft, established on the basis of comments received, will be submitted to a parallel two-month approval vote in ISO and formal vote in CEN.

© International Organization for Standardization, 2011

## ISO 12836 - Dentistry, Digitizing devices used in CAD/CAM systems

Two dies with a center to center distance of 30 mm for edge testing

The dimensions are:

- a =  $(7 \pm 0,5)$  mm
- b =  $e/2$
- c =  $(2,6 \pm 0,1)$  mm
- d =  $(30 \pm 1)$  mm
- e =  $(10 \pm 0,5)$  mm
- f =  $(10 \pm 0,5)$  mm
- g =  $(4 \pm 0,5)$  mm
- h =  $(4 \pm 0,5)$  mm
- $\alpha$  =  $(16 \pm 1)^\circ$
- r = 0,02 mm
- s = 0,02 mm
- t = 0,02 mm

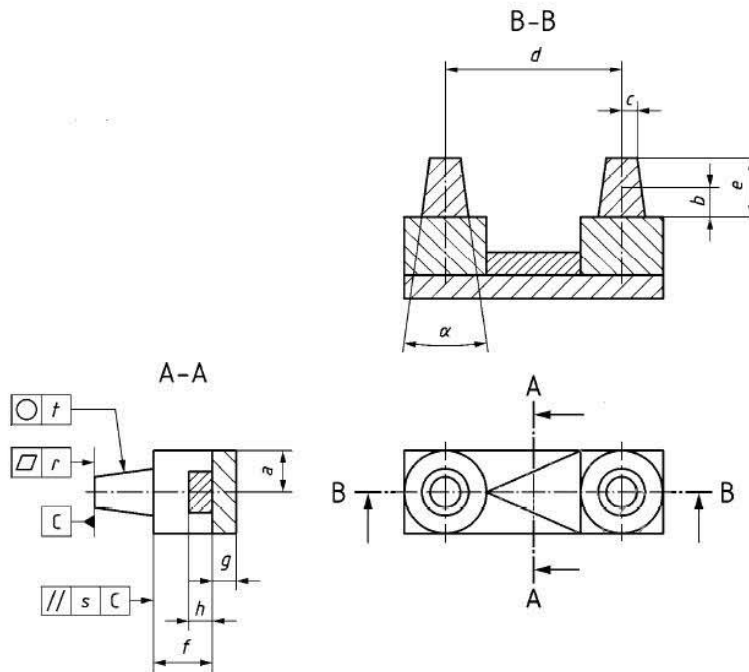

This draft has been developed within the International Organization for Standardization (ISO), and processed under the ISO-lead mode of collaboration as defined in the Vienna Agreement.

This draft is hereby submitted to the ISO member bodies and to the CEN member bodies for a parallel five-month enquiry.

Should this draft be accepted, a final draft, established on the basis of comments received, will be submitted to a parallel two-month approval vote in ISO and formal vote in CEN.

© International Organization for Standardization, 2011